

Last Name: _____ First Name _____ Network-ID _____

Discussion Section: _____ Discussion TA Name: _____

Turn off your cell phone and put it out of sight.

Keep your calculator on your own desk. Calculators cannot be shared.

This is a closed book exam. You have ninety (90) minutes to complete it.

1. Use a #2 pencil. Do not use a mechanical pencil or pen. Darken each circle completely, but stay within the boundary. If you decide to change an answer, erase vigorously; the scanner sometimes registers incompletely erased marks as intended answers; this can adversely affect your grade. Light marks or marks extending outside the circle may be read improperly by the scanner. Be especially careful that your mark covers the **center** of its circle.
2. You may find the version of **this Exam Booklet at the top of page 2**. Mark the version circle in the TEST FORM box near the middle of your answer sheet. **DO THIS NOW!**
3. Print your **NETWORK ID** in the designated spaces at the *right* side of the answer sheet, starting in the left most column, then **mark the corresponding circle** below each character. If there is a letter "o" in your NetID, be sure to mark the "o" circle and not the circle for the digit zero. If and only if there is a hyphen "-" in your NetID, mark the hyphen circle at the bottom of the column. When you have finished marking the circles corresponding to your NetID, check particularly that you have not marked two circles in any one of the columns.
4. Print **YOUR LAST NAME** in the designated spaces at the *left* side of the answer sheet, then mark the corresponding circle below each letter. Do the same for your **FIRST NAME INITIAL**.
5. Print your UIN# in the STUDENT NUMBER designated spaces and mark the corresponding circles. You need not write in or mark the circles in the SECTION box.
6. Sign your name (**DO NOT PRINT**) on the **STUDENT SIGNATURE line**.
7. On the **SECTION line**, print your **DISCUSSION SECTION**. You need not fill in the COURSE or INSTRUCTOR lines.

*Before starting work, check to make sure that your test booklet is complete. You should have 16 **numbered pages** plus three (3) Formula Sheets.*

Academic Integrity—Giving assistance to or receiving assistance from another student or using unauthorized materials during a University Examination can be grounds for disciplinary action, up to and including dismissal from the University.

This Exam Booklet is Version A. Mark the **A** circle in the **TEST FORM** box near the middle of your answer sheet. **DO THIS NOW!**

Exam Grading Policy—

The exam is worth a total of **114** points, composed of three types of questions.

MC5: *multiple-choice-five-answer questions, each worth 6 points.*

Partial credit will be granted as follows.

- (a) If you mark only one answer and it is the correct answer, you earn **6** points.
- (b) If you mark *two* answers, one of which is the correct answer, you earn **3** points.
- (c) If you mark *three* answers, one of which is the correct answer, you earn **2** points.
- (d) If you mark no answers, or more than *three*, you earn **0** points.

MC3: *multiple-choice-three-answer questions, each worth 3 points.*

No partial credit.

- (a) If you mark only one answer and it is the correct answer, you earn **3** points.
- (b) If you mark a wrong answer or no answers, you earn **0** points.

MC2: *multiple-choice-two-answer questions, each worth 2 points.*

No partial credit.

- (a) If you mark only one answer and it is the correct answer, you earn **2** points.
- (b) If you mark the wrong answer or neither answer, you earn **0** points.

Some helpful information:

- A reminder about prefixes: p (pico) = 10^{-12} ; n (nano) = 10^{-9} ; μ (micro) = 10^{-6} ; m (milli) = 10^{-3} ; k (kilo) = 10^{+3} ; M or Meg (mega) = 10^{+6} ; G or Gig (giga) = 10^{+9} .

The next four questions pertain to the following situation:

A pencil of height $H_0 = 10$ cm is placed a distance x in front of a concave mirror (of focal length $f = +15$ cm) as shown in the figure below.

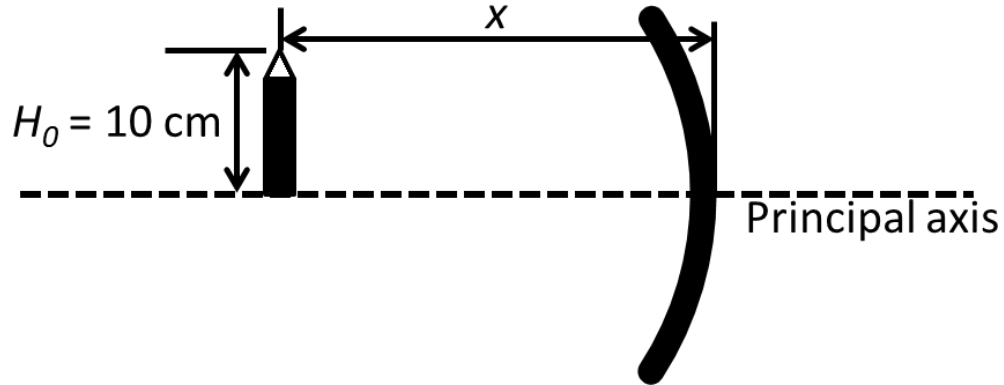

1. What is the radius of curvature R of the mirror?
 - a. $R = 30$ cm
 - b. $R = 15$ cm
 - c. $R = 7.5$ cm

2. At what position x in front of the mirror should the pencil be placed such that its image appears to be 60 cm behind the mirror?
 - a. $x = 3$ cm
 - b. $x = 6$ cm
 - c. $x = 12$ cm
 - d. $x = 24$ cm
 - e. $x = 48$ cm

(problem continues from previous page)

3. If the pencil is placed at a position $x = 90$ cm in front of the mirror, what will be the height H_i of the pencil's image?

- a. $H_i = 1$ cm
- b. $H_i = 2$ cm
- c. $H_i = 4$ cm
- d. $H_i = 8$ cm
- e. $H_i = 16$ cm

4. For which values of x will the image of the pencil be real?

- a. $x > 15$ cm
- b. $x < 15$ cm
- c. The image will always be virtual.

5. Which of the following figures correctly represents a ray reflected off a convex mirror?

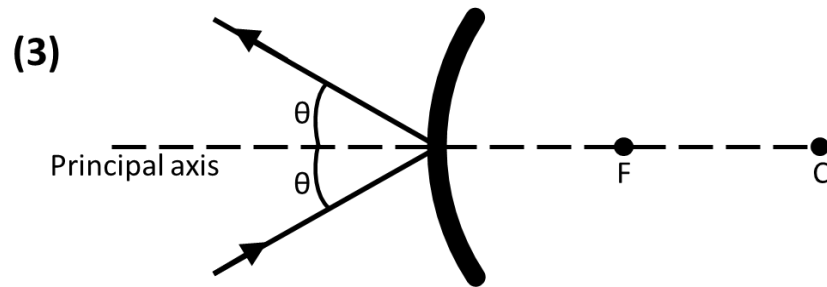
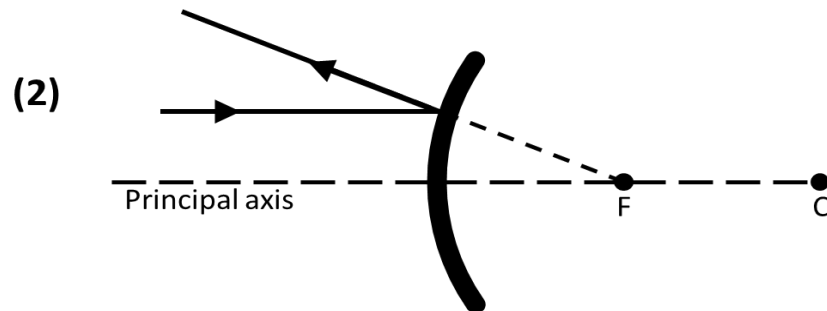
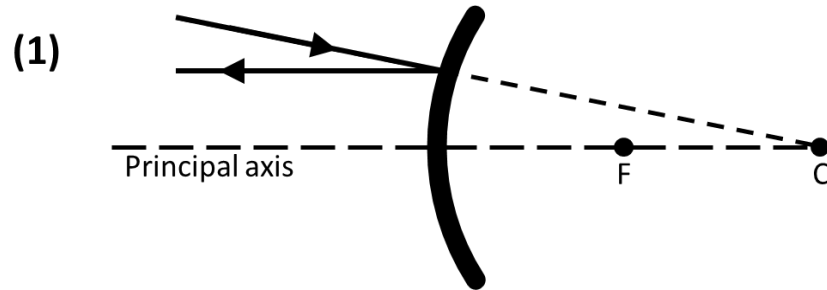

- a. (1)
- b. (2)
- c. (3)
- d. (1) and (2)
- e. (2) and (3)

6. An object is placed 14 cm in front of a spherical mirror of unknown shape and focal length. The resulting image is located 7 cm behind the mirror. Is the mirror concave or convex?

- Concave
- Convex
- It cannot be determined from the information given

7. The Gateway Arch, located in St. Louis, Missouri, is $H = 192$ m in height. If you view it with your unaided eye from a distance of 1.5 km, what is the size of its image h that is formed on the retina of your eye? Your eye is 25 mm from pupil to retina. You may assume the small angle approximation for this problem. (Picture is not to scale.)

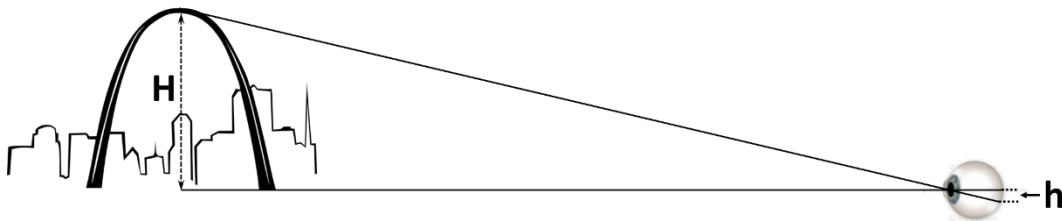

- $h = 3.2$ mm
- $h = 23.1$ mm
- $h = 9.4$ mm
- $h = 1.9$ mm
- $h = 0.72$ mm

8. A student with a laser pointer is located a distance $h = 2$ m away from a mirror of length $L = 7$ m, as shown in the figure below. (The figure is not to scale.) The laser beam from the pointer is reflected off the mirror and subsequently hits a sensor located a distance $y = 3$ m away from the mirror; the sensor is located on a wall adjacent to and perpendicular to the mirror.

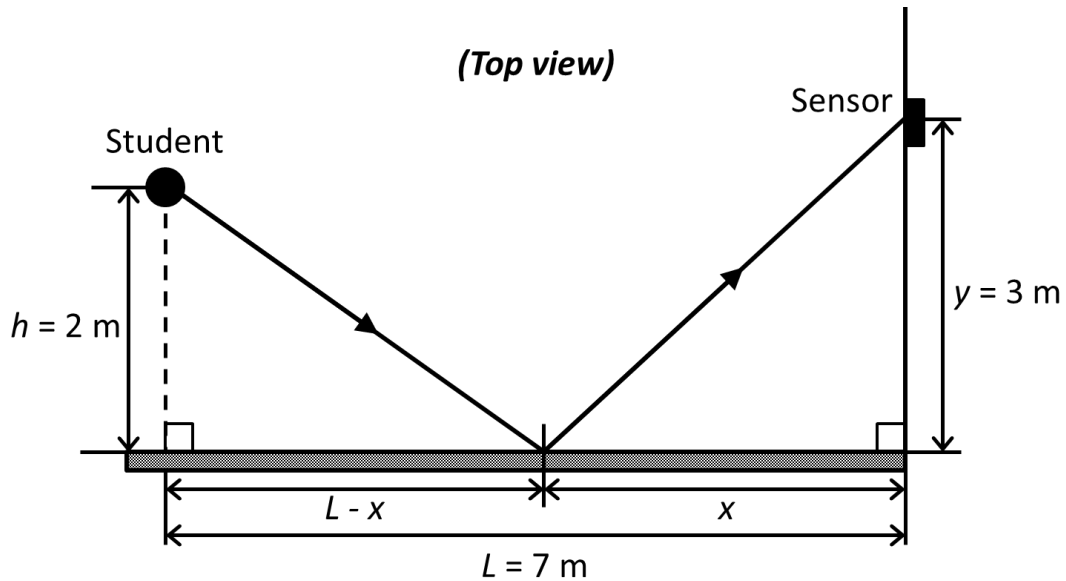

At what distance x away from the wall must the incident beam hit the mirror?

- a. $x = 2.8$ m
- b. $x = 1.0$ m
- c. $x = 3.6$ m
- d. $x = 5.4$ m
- e. $x = 4.2$ m

The next two questions pertain to the following situation:

Bob stands in front of a flat mirror whose bottom is a height y above the floor, as shown in the figure. Bob's eyes are 1.72 m above the floor.

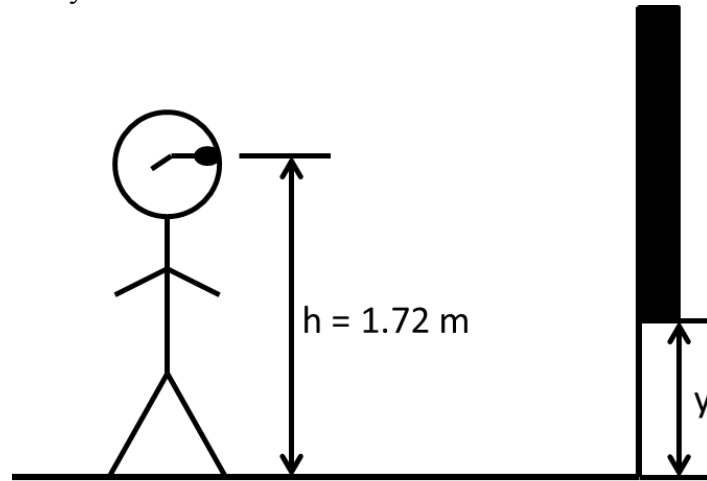

9. At what maximum height y_{max} can the mirror be placed above the ground such that Bob can still see his feet in the mirror?

- a. $y_{max} = 0.43$ m
- b. $y_{max} = 0.86$ m
- c. $y_{max} = 1.29$ m
- d. $y_{max} = 0.65$ m
- e. $y_{max} = 1.72$ m

10. Alice runs towards the mirror at a speed of 8 m/s while Bob stands still. What is the speed v_i of Alice's image in the mirror according to Bob?

- a. $v_i = 4$ m/s
- b. $v_i = 8$ m/s
- c. $v_i = 16$ m/s

11. A blue underwater decorative lamp is located on the bottom of a pool. The pool is 4 m deep. The index of refraction for blue light in water is $n_{\text{water,blue}} = 1.34$. The rays of light shown are at the maximum angle that can refract to the air.

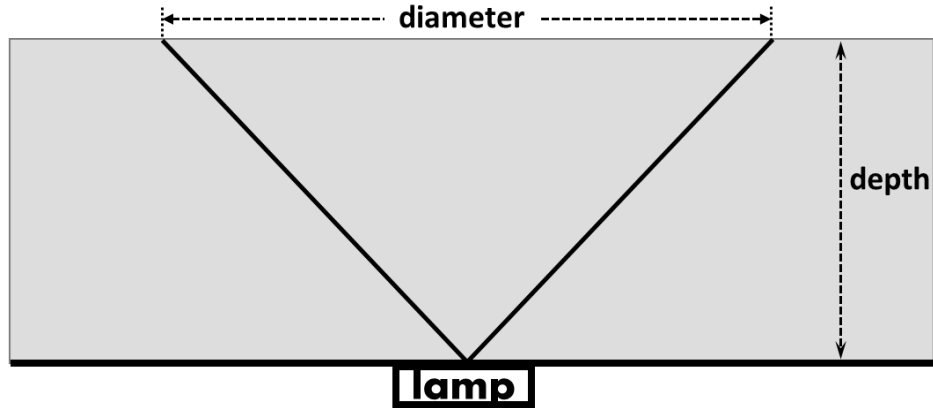

What is the diameter of the circle of blue light D_{blue} from this lamp observed on the surface of the pool (as indicated in the figure)?

- a. $D_{\text{blue}} = 14.5$ m
- b. $D_{\text{blue}} = 2.2$ m
- c. $D_{\text{blue}} = 9.0$ m
- d. $D_{\text{blue}} = 30.8$ m
- e. $D_{\text{blue}} = 4.0$ m

The next four questions pertain to the following situation:

An object is placed 3 cm in front of a diverging lens of focal length $f = -8$ cm.

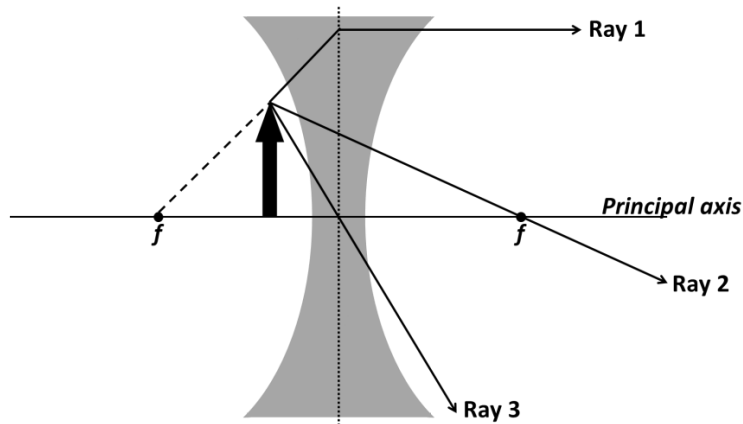

12. Identify the correct principal ray in the above sketch.

- a. Ray 1
- b. Ray 2
- c. Ray 3

13. Calculate the location of the image formed by the lens.

- a. $d_i = +3.0$ cm
- b. $d_i = -4.8$ cm
- c. $d_i = -2.2$ cm

14. What is the orientation of the image formed by the diverging lens relative to its object?

- a. upright
- b. inverted

15. Now let the diverging lens be replaced by a converging lens of equal but opposite focal length ($f_{new} = +8$ cm). For the same object distance, what is the nature of image formed by the converging lens?

- a. real
- b. virtual

16. A microscope has an objective lens with focal length $f_{obj} = +10$ mm and an eyepiece lens with focal length $f_{eye} = +40$ mm. The two lenses are positioned 68 mm apart in the barrel of the microscope. An object to be viewed is placed 15 mm in front of the objective lens.

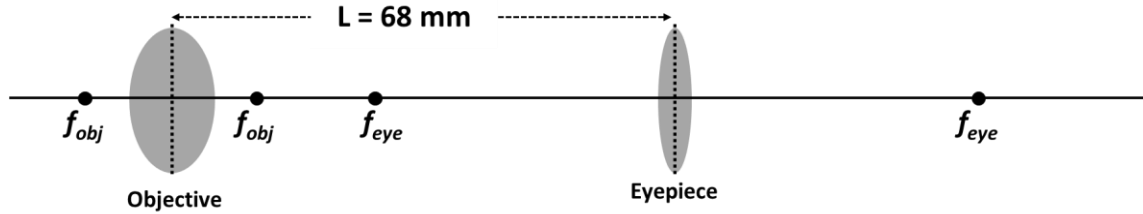

What is the magnitude of the total magnification $|m_{total}|$ of the microscope for this object?

- a. $|m_{total}| = 300$
- b. $|m_{total}| = 40$
- c. $|m_{total}| = 5$
- d. $|m_{total}| = 70$
- e. $|m_{total}| = 1200$

17. What is the power of contact lenses needed for a person whose near point is 60 cm to read comfortably a book placed 28 cm from her eyes?

- a. +1.90 diopters
- b. +52.9 diopters
- c. -2.26 diopters
- d. +10.4 diopters
- e. -7.32 diopters

The next two questions pertain to the following situation:

In the following experiment, light of wavelength $\lambda = 633 \text{ nm}$ from a red laser illuminates a double slit. An interference pattern is observed on a screen placed 5 m away. (You may use the small angle approximation throughout.)

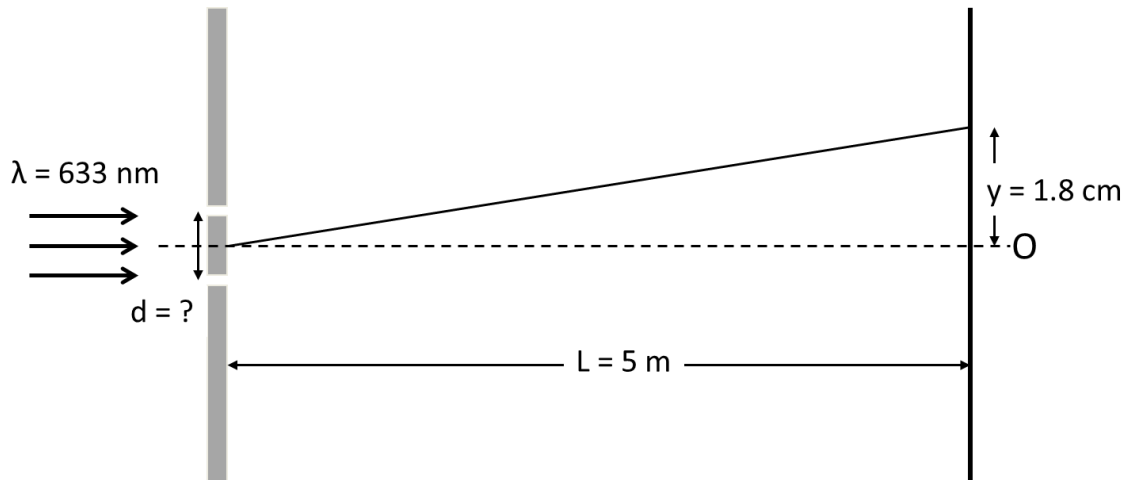

18. If the second order bright fringe is at a position $y = 1.8 \text{ cm}$ on the screen, what is the separation d between the two slits?

- $d = 1.2 \text{ mm}$
- $d = 0.89 \text{ mm}$
- $d = 0.67 \text{ mm}$
- $d = 2.7 \text{ mm}$
- $d = 0.35 \text{ mm}$

19. A material is inserted just behind the bottom slit that causes the bottom ray to be shifted by $\lambda/2$. Which of the following drawings best represents the interference pattern seen on the screen?

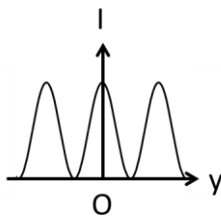

(1)

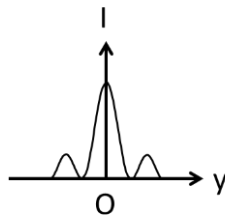

(2)

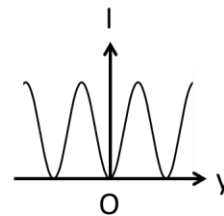

(3)

- (1)
- (2)
- (3)

The next two questions pertain to the following situation:

The lenses on your reading glasses have a thin anti-reflection coating on them. The lenses are made of plastic with an index of refraction $n_{lens} = 1.53$, and the coating is made from a material with index of refraction $n_{coat} = 1.20$.

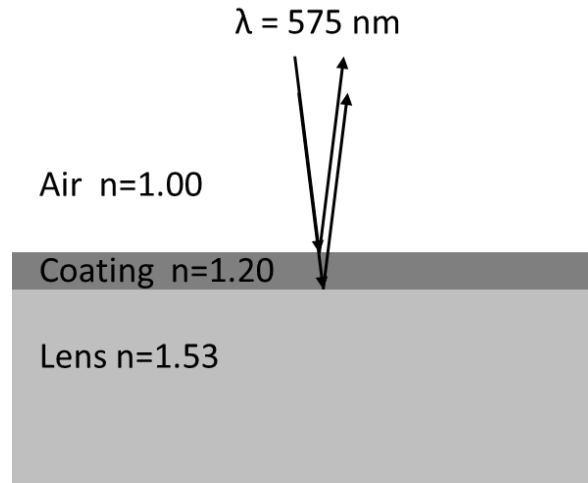

20. The coating works in such a way that yellow light of wavelength $\lambda = 575 \text{ nm}$ (in vacuum) is NOT reflected. Which of the following is a possible value for the coating thickness t ?

- a. $t = 167 \text{ nm}$
- b. $t = 203 \text{ nm}$
- c. $t = 120 \text{ nm}$

21. Would yellow light ($\lambda = 575 \text{ nm}$) still destructively interfere if the glasses were worn under water ($n_{water} = 1.33$)?

- a. Yes
- b. No

22. On a clear night you see a small airplane flying toward you, approaching for a landing at Willard airport. The jet has red lights of wavelength $\lambda = 650 \text{ nm}$ on each wing, 2.8 m apart, but from far away you can only make out one light.

How close must the airplane get to you for you to start just making out the two wing lights? Assume that you have perfect vision and that your pupil diameter is 2.5 mm. (You may use the small angle approximation.)

- a. 12 km
- b. 8.8 km
- c. 53 km
- d. 24 km
- e. 9.6 km

23. You are driving along a stretch of highway. As shown in the figure below, two AM radio towers are 5 km apart alongside the highway and are emitting coherent radio waves of frequency $f = 1010 \text{ kHz}$. You discover that you cannot listen to the AM radio station in your car at your present location L because there is complete destructive interference of the two radio waves.

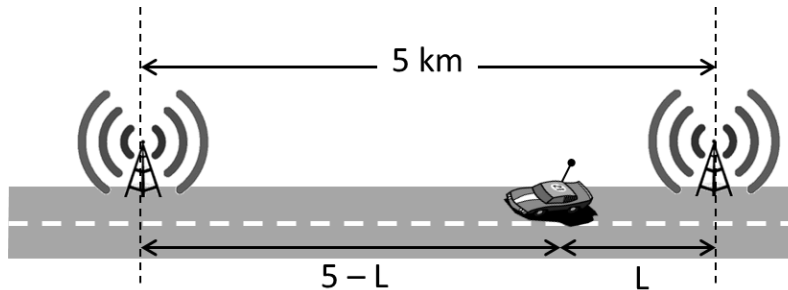

What is the smallest distance you need to drive further to get complete constructive interference and be able to hear the station? (Note: the value of L is unknown and irrelevant.)

- a. 27.1 m
- b. 74.3 m
- c. 15.1 m
- d. 467 m
- e. 832 m

The next two questions pertain to the following situation:

At your grandparents' house you discover two old "walkie-talkies", i.e. handheld radio emitters/receivers. Your friend uses one as an emitter inside the house, while you stand outside using the other as a receiver. Your friend stands inside, behind the front door, which you can treat as a slit of width $w = 90$ cm.

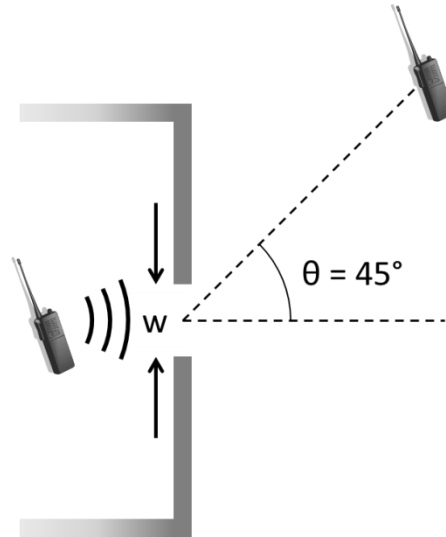

24. You notice that if you stand outside at an angle of 45° relative to the doorway, you DO NOT receive your friend's radio signal because of destructive interference. What is the frequency f of the radio wave?

- a. $f = 471$ MHz
- b. $f = 333$ MHz
- c. $f = 647$ MHz

25. Suppose you can change the frequency of the radio signal. What maximum frequency f_{max} could you use so that there is NO destructive interference anywhere outside?

- a. $f_{max} = 471$ MHz
- b. $f_{max} = 333$ MHz
- c. $f_{max} = 647$ MHz

The next two questions pertain to the following situation:

As shown in the figure below, a three-slit grating is used to demonstrate interference. The slits are equally spaced apart by a distance d . Monochromatic laser light of wavelength λ illuminates the grating.

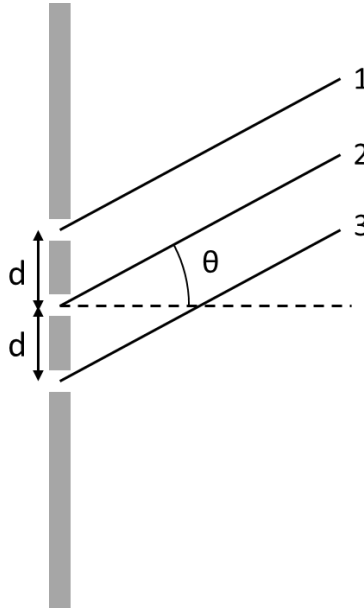

At the angle shown, rays 1 and 3 interfere destructively. Each ray has intensity I_0 .

26. At this angle, what is the total intensity I_{tot} of the light on a screen far away?

- a. $I_{tot} = 0$
- b. $I_{tot} = I_0$
- c. $I_{tot} = 3I_0$

27. Now suppose that a 4th slit is added, such that all 4 slits are equally spaced by the same distance d as before. At the same angle as above, what is the total intensity I_{tot} of the light on a screen far away?

- a. $I_{tot} = 0$
- b. $I_{tot} = I_0$
- c. $I_{tot} = 3I_0$

**Check to make sure you bubbled in all your answers.
Did you bubble in your name, exam version and network-ID?**