

Last Name: _____ First Name _____ Network-ID _____

Discussion Section: _____ Discussion TA Name: _____

Turn off your cell phone and put it out of sight.

Keep your calculator on your own desk. Calculators cannot be shared.

This is a closed book exam. You have ninety (90) minutes to complete it.

1. Use a #2 pencil. Do not use a mechanical pencil or pen. Darken each circle completely, but stay within the boundary. If you decide to change an answer, erase vigorously; the scanner sometimes registers incompletely erased marks as intended answers; this can adversely affect your grade. Light marks or marks extending outside the circle may be read improperly by the scanner. Be especially careful that your mark covers the **center** of its circle.
2. You may find this version of **this Exam Booklet at the top of page 2**. Mark the **version** circle in the **TEST FORM** box near the bottom right on the face of your answer sheet. **DO THIS NOW!**
3. Print your **NETWORK ID** in the designated spaces at the *right* side of the answer sheet, starting in the left most column, then **mark the corresponding circle** below each character. If there is a letter "o" in your NetID, be sure to mark the "o" circle and not the circle for the digit zero. If and only if there is a hyphen "-" in your NetID, mark the hyphen circle at the bottom of the column. When you have finished marking the circles corresponding to your NetID, check particularly that you have not marked two circles in any one of the columns.
4. Print **YOUR LAST NAME** in the designated spaces at the *left* side of the answer sheet, then mark the corresponding circle below each letter. Do the same for your **FIRST NAME INITIAL**.
5. Print your UIN# in the **STUDENT NUMBER** designated spaces and mark the corresponding circles. You need not write in or mark the circles in the **SECTION** box.
6. Sign your name (**DO NOT PRINT**) on the **STUDENT SIGNATURE line**.
7. On the **SECTION line**, print your **DISCUSSION SECTION**. You need not fill in the **COURSE** or **INSTRUCTOR** lines.

Before starting work, check to make sure that your test booklet is complete. You should have 14 numbered pages plus three Formula Sheets.

Academic Integrity—Giving assistance to or receiving assistance from another student or using unauthorized materials during a University Examination can be grounds for disciplinary action, up to and including dismissal from the University.

This Exam Booklet is Version A. Mark the **A** circle in the **TEST FORM** box near the bottom right on the face of your answer sheet. **DO THIS NOW!**

Exam Grading Policy—

The exam is worth a total of **129** points, composed of three types of questions.

MC5: *multiple-choice-five-answer questions, each worth 6 points.*

Partial credit will be granted as follows.

- (a) If you mark only one answer and it is the correct answer, you earn **6** points.
- (b) If you mark *two* answers, one of which is the correct answer, you earn **3** points.
- (c) If you mark *three* answers, one of which is the correct answer, you earn **2** points.
- (d) If you mark no answers, or more than *three*, you earn **0** points.

MC3: *multiple-choice-three-answer questions, each worth 3 points.*

No partial credit.

- (a) If you mark only one answer and it is the correct answer, you earn **3** points.
- (b) If you mark a wrong answer or no answers, you earn **0** points.

MC2: *multiple-choice-two-answer questions, each worth 2 points.*

No partial credit.

- (a) If you mark only one answer and it is the correct answer, you earn **2** points.
- (b) If you mark the wrong answer or neither answer, you earn **0** points.

Some helpful information:

- A reminder about prefixes: p (pico) = 10^{-12} ; n (nano) = 10^{-9} ; μ (micro) = 10^{-6} ; m (milli) = 10^{-3} ; k (kilo) = 10^{+3} ; M or Meg (mega) = 10^{+6} ; G or Gig (giga) = 10^{+9} .

The following situation pertains to the next two questions:

Three circuits are shown below. Each is driven by an AC generator with a frequency of 60 Hz and an rms voltage of 120 V.

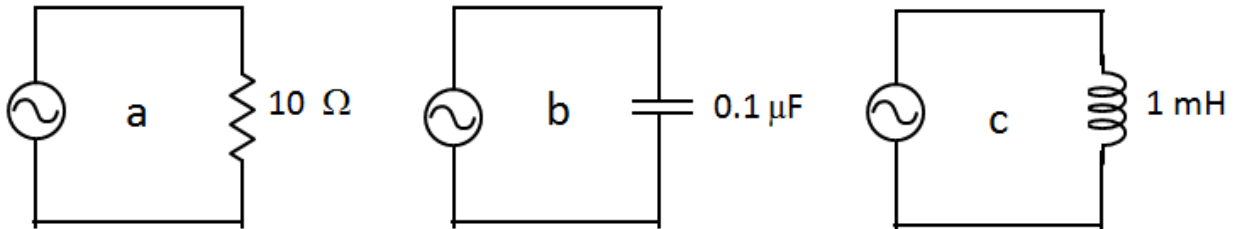

1. Which circuit has the largest maximum current?

- a. a
- b. b
- c. c

2. In which circuit is the most power supplied by the AC generator?

- a. a
- b. b
- c. c

The following situation pertains to the next two questions:

A transformer is used in the power supply for your computer to reduce the voltage supplied by a wall outlet. 120 V rms from the outlet is applied to the primary side of the transformer, and 20 V rms is produced on the secondary side of the transformer, which is connected to the computer. The rms current on the primary side of the transformer is 0.5 A.

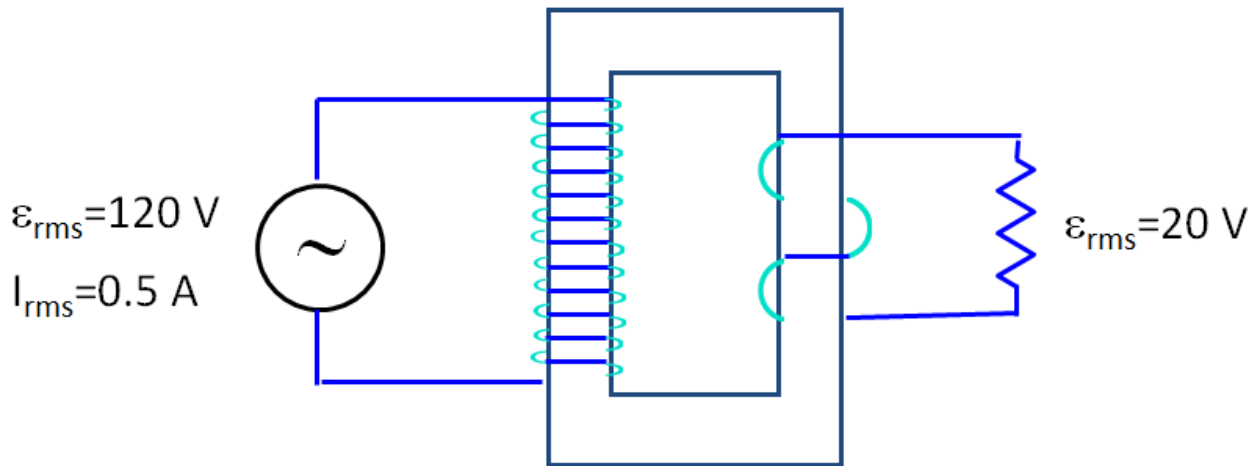

3. What is the rms current on the secondary side of the transformer?

- a. 0.08 A
- b. 3 A
- c. 0.5 A

4. How much power is supplied to the computer?

- a. 60 W
- b. 10 W
- c. 1.6 W

5. How much current must flow in a 3H inductor to supply the energy required to launch a 1 kg piece of metal to a 10 m height?

- a. 0 A
- b. 6.7 A
- c. 0.12 A
- d. 0.015 A
- e. 8.1 A

6. Each inductor in the coil pack in your car has a 1 mH inductance. If the inductors are created by wrapping wire around a cylinder with a 0.005 m radius and 0.01 m length to make a solenoid, how many turns of wire are required?

- a. 10,000
- b. 320
- c. 32,000
- d. 20
- e. 560

7. What frequency should be applied to an RLC circuit with $R=30\ \Omega$, $C=1.5\ \text{pF}$, and $L=0.01\ \mu\text{H}$ in order to achieve the largest maximum current?

- a. 1.5 GHz
- b. 1.8 GHz
- c. 0.15 GHz
- d. 8.2 GHz
- e. 1.3 GHz

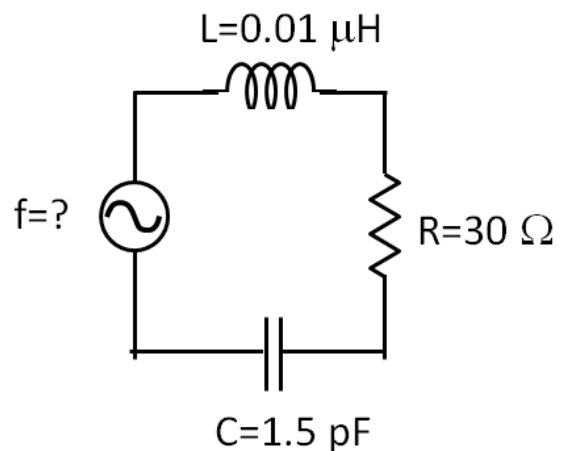

8. A 10^{-5} m long carbon nanotube with a mass of 2×10^{-20} kg is used as a wire. As shown, the nanotube carries 10^{-9} A of current to the right. If the Earth's magnetic field is 5×10^{-5} T and points into the page, what is the acceleration of the nanotube?

- a. 9.8 m/s^2
- b. 25 m/s^2
- c. $5 \times 10^{-9} \text{ m/s}^2$
- d. 0.04 m/s^2
- e. $2.5 \times 10^{-19} \text{ m/s}^2$

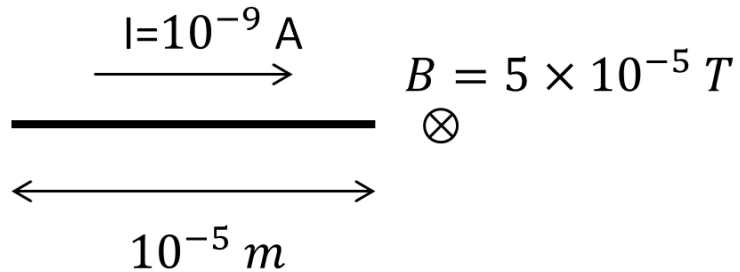

9. Two spaceships are engaged in a battle using laser cannons, as shown below. When at rest, the laser cannons emit light with frequency $f = 2.8 \times 10^{14}$ Hz. The ship on the left is traveling to the right at 2000 km/s, and the ship on the right is traveling to the right at 1000 km/s. When the ship on the left fires its cannon, the ship on the right observes light with frequency f' . What is $f' - f$?

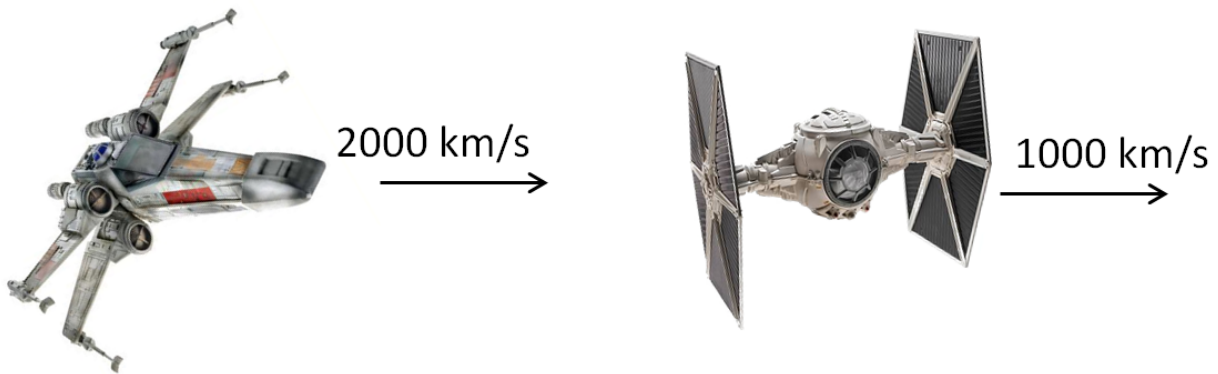

- a. 0 Hz
- b. -1.9×10^{12} Hz
- c. 1.9×10^{12} Hz
- d. 9.3×10^{11} Hz
- e. -9.3×10^{11} Hz

The following situation pertains to the next three questions:

A generator coil rotates in a uniform and constant magnetic field of $B = 1\text{ T}$. The coil has 10 windings and the rotation frequency of the coil in the field is $f = 0.5\text{ Hz}$ ($\Omega = 3.14\text{ rad/s}$). The resistance of all conductors in the circuit can be neglected. However, there is an external load resistor of $R = 10\ \Omega$. The coil rotates around the y -axis in the direction indicated by the circular arrow in the drawing below. Looking along the y -axis, the rotation is counterclockwise (i.e., the side **ab** of the wire loop moves into the page). The area of the coil is 1 m^2 .

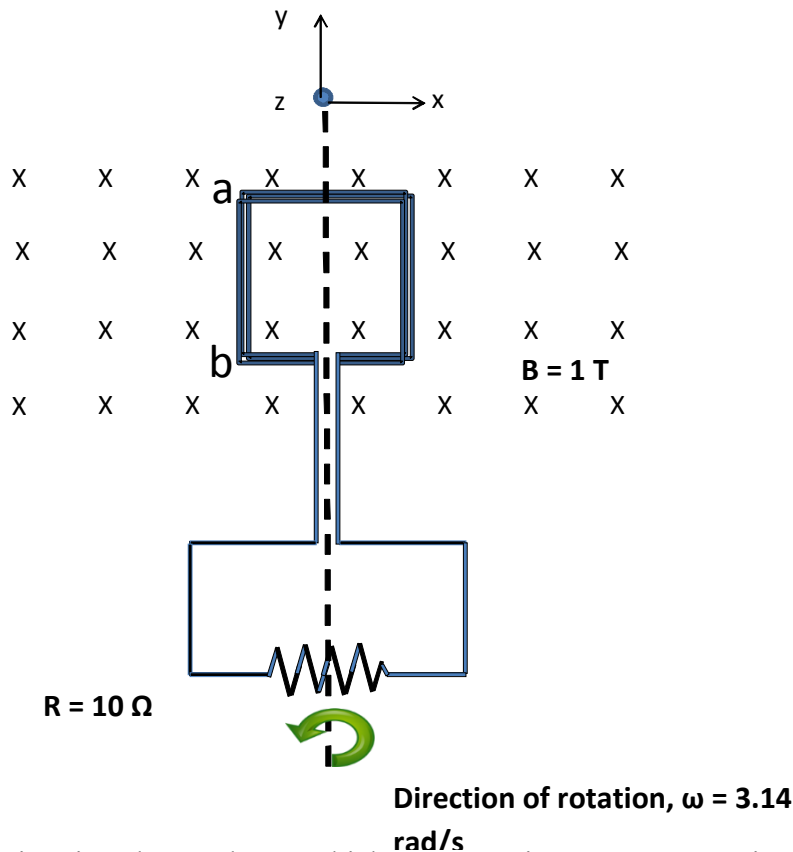

10. For the situation shown above, which statement is correct concerning the magnitude of the current?

- a. The current reaches its maximum value in the clockwise direction.
- b. The current reaches its maximum value in the counter-clockwise direction.
- c. The current is zero.

11. When the generator coil has rotated by an angle of 30 degrees starting from the situation shown above, what is the direction of the current?

- a. from a to b

- b. from b to a
- c. zero

12. What is the maximum current through the resistor?

- a. 3.14 A
- b. 2.67 A
- c. 1.33 A
- d. 1.0 A
- e. 0.1 A

The following situation pertains to the next two questions:

A metal frame with an internal resistance of $1 \text{ m}\Omega$ enters a region of a uniform magnetic field $B = 1 \text{ T}$. The area of the frame is 1 m^2 . The velocity of the frame, v , is constant. At $t = 0$, the upper edge of the frame reaches the boundary of the magnetic field. From this point of time it takes 10 seconds for the frame to fully enter the magnetic field. After 30 seconds of uniform motion the frame exits the magnetic field region again.

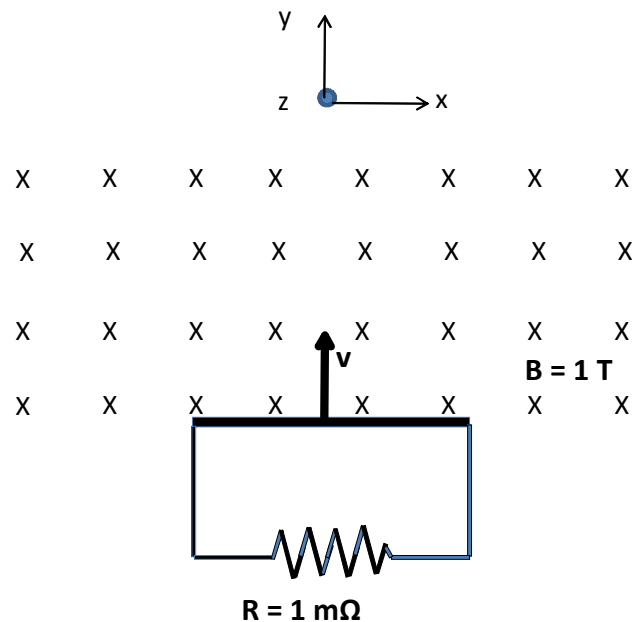

13. From Lenz's rule, what is the relation between the currents induced in the metal frame on entrance to and upon exit from the magnetic field?

- a. Entrance: clockwise Exit: clockwise
- b. Entrance: clockwise Exit: counterclockwise
- c. Entrance: counterclockwise Exit: clockwise

14. What is the maximum magnitude of the induced current?

- a. 1000.0 A
- b. 100.0 A
- c. 10.0 A
- d. 1.0 A
- e. 0.1 A

The following situation pertains to the next three questions:

Electromagnetic waves emitted from a cellular phone propagate in the x-direction as shown in the figure below. The frequency of the wave is $f=900$ MHz.

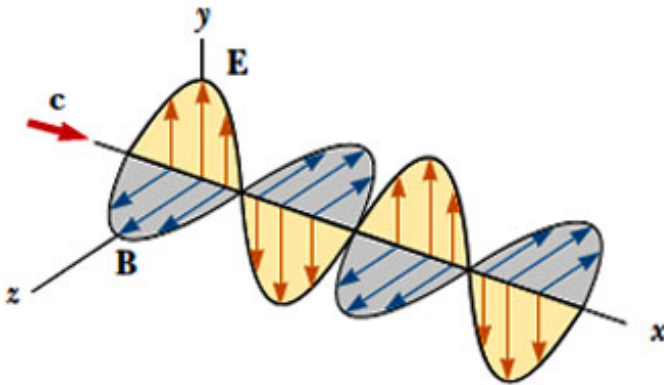

15. How long does it take for the wave to travel from the cell phone to a cell tower 5 km away?

- a. 13.3 μs
- b. 16.7 μs
- c. 13.3 ns
- d. 16.7 ns
- e. 1.33 ms

16. What is the wavelength of the electromagnetic wave?

- a. 3.00 μm
- b. 0.33 mm
- c. 33.3 cm

17. The polarization of the wave is in the

- a. x-direction.
- b. y-direction.
- c. z-direction.

18. The International Space Station (ISS) is powered by 8 wings of solar cell arrays. Each array has an area of 375 m^2 . The solar cells turn 6% of the energy of the sunlight into electric energy. If the rms magnitude of the electric field of the sun light incident on the solar cell arrays is 715 V/m , how much electrical power do the 8 wings of solar cell arrays provide to the ISS ?

- a. 300 kW
- b. 144 kW
- c. 244 kW
- d. 18 kW
- e. 30 kW

19. A long straight wire carries current, I_1 . It produces a magnetic field, B_1 , at a distance, d_1 , from the wire. Now, both the current and the distance are doubled.

Compare the new magnetic field, B_2 , to the original field, B_1 .

- a. $B_2 < B_1$
- b. $B_2 = B_1$
- c. $B_2 > B_1$

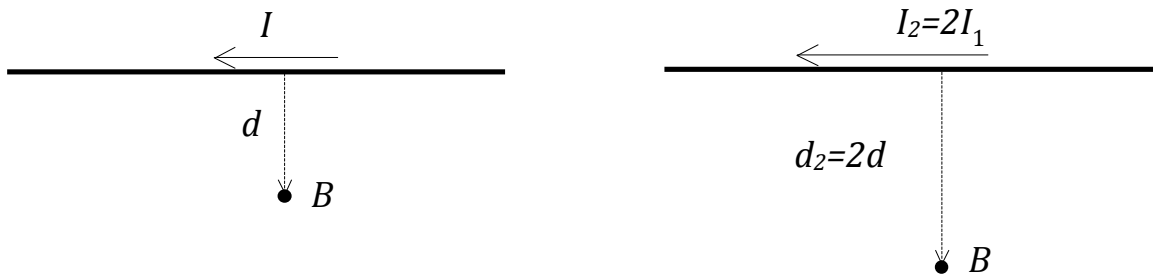

20. Two wires carry current perpendicular to the page. The magnitudes of the two currents are equal, but one is into and one is out of the page, as shown. Where on the line is the magnetic field zero?

- a. Somewhere in region A
- b. Somewhere in region B
- c. At point C
- d. Somewhere in region D
- e. The magnetic field is not zero anywhere on the line.

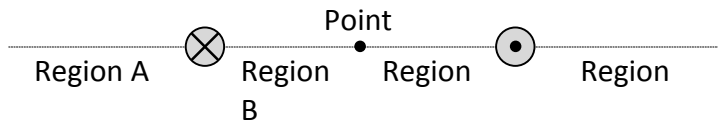

21. The coil of an MRI solenoid is 8 cm long and has a 0.025 m radius. There are 500 turns of wire. How much current is needed to produce a 3 T magnetic field inside the solenoid? (Note: This device images mice, not humans!)

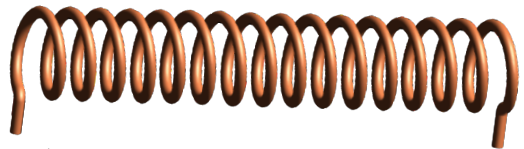

- a. $I = 6.0 \times 10^{-10}$ A
- b. $I = 382$ A
- c. $I = 4774$ A
- d. $I = 1.91 \times 10^5$ A
- e. $I = 1.49 \times 10^{10}$ A

The next two questions pertain to this situation:

A charged dust particle ($m = 3 \times 10^{-21}$ kg, $q = +1.6 \times 10^{-16}$ C) is accelerated from rest by an electric field through a 10^3 V potential difference. The magnetic field is zero in the electric field region. It then enters a region that contains a uniform 1.5 T magnetic field that points into the page. $E = 0$ in the magnetic field region.

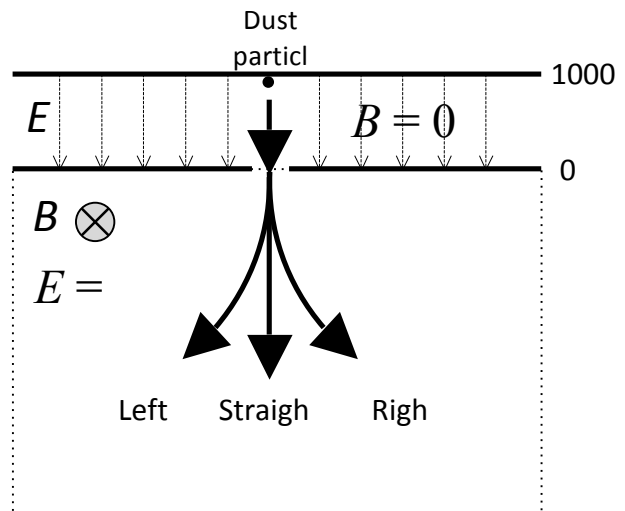

22. Which of the three paths shown in the figure does the dust particle follow?

- a. Left
- b. Straight
- c. Right

23. What is the radius of curvature of the particle's motion in the magnetic field region?

- a. $R = 0.022$ m
- b. $R = 0.129$ m
- c. $R = 1.53$ m
- d. $R = 15.3$ m
- e. $R = 1096$ m

24. A negatively charged particle, $-q$, is moving in the $+z$ direction in a region that contains a uniform magnetic field along the $-x$ direction. In what direction must an electric field point so that there is no net force on the particle?

- a. Along $+x$
- b. Along $-x$
- c. Along $+y$
- d. Along $-y$
- e. Along $-z$

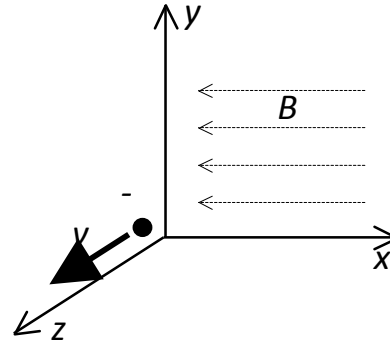

25. An electron (mass: $m = 9.11 \times 10^{-31}$ kg, and charge: $q = -1.60 \times 10^{-19}$ C) is initially at point P_1 with speed $v_1 = 3.1 \times 10^4$ m/s. It is moving in a uniform magnetic field of strength $B = 0.15$ T. How fast (v_2) is the electron moving when it reaches point P_2 , which is $d_1 = 2.5 \times 10^{-7}$ m along B and $d_2 = 1.5 \times 10^{-7}$ m perpendicular to B with respect to P_1 ?

- a. $v_2 = 1.1 \times 10^4$ m/s
- b. $v_2 = 3.1 \times 10^4$ m/s
- c. $v_2 = 5.1 \times 10^4$ m/s
- d. $v_2 = 6.7 \times 10^4$ m/s
- e. The electron does not have enough energy to reach point P_2 .

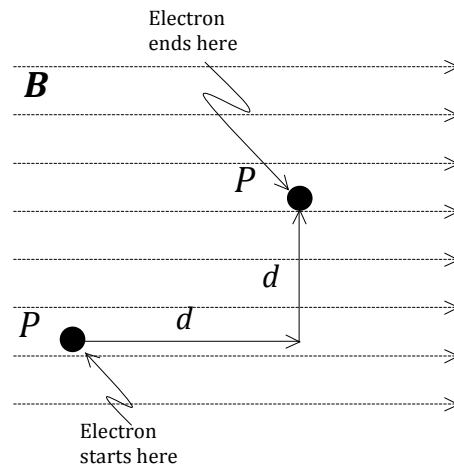

The next two questions pertain to this situation.

A square loop with sides, $L = 0.1$ m, lies in the x - z plane and carries electric current, $I = 3.7$ A, in the direction shown. The magnetic field, $B = 0.22$ T, lies in the x - y plane, rotated away from the $+y$ direction by an angle θ , as shown.

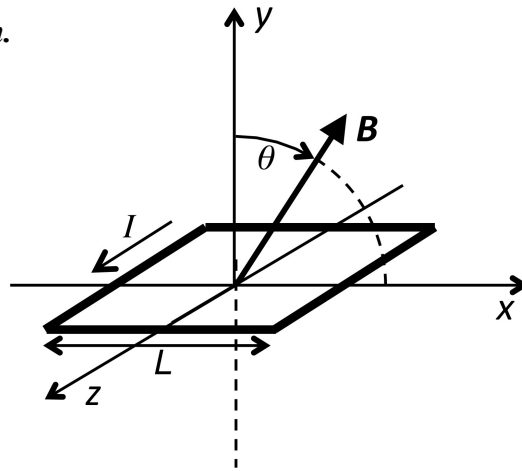

26. What value of θ would make the torque on the loop equal to zero?

- a. $\theta = 0^\circ$
- b. $\theta = 45^\circ$
- c. $\theta = 90^\circ$
- d. $\theta = -90^\circ$
- e. The torque is never equal to zero.

27. For $\theta = 37^\circ$, how much torque, τ , is exerted on the loop?

- a. $\tau = 4.90 \times 10^{-3}$ N·m
- b. $\tau = 6.50 \times 10^{-3}$ N·m
- c. $\tau = 8.14 \times 10^{-3}$ N·m
- d. $\tau = 2.23 \times 10^{-2}$ N·m
- e. $\tau = 8.14 \times 10^{-2}$ N·m

**Check to make sure you bubbled in all your answers.
Did you bubble in your name, exam version and network-ID?**